

Technical data sheet



Product features

Sausage/vegetable steamer with tap GN 1/2

Model	SAP Code	00005200
--------------	-----------------	----------



- Material: Stainless steel
- Indicators: operation and warm-up
- Minimum device temperature [°C]: 30
- Maximum device temperature [°C]: 90
- Number of GN / EN: 2
- GN / EN size in device: GN 1/2
- GN device depth: 150
- Heating location: Under the bottom of the bathtub
- False bottom: Yes
- Standard equipment for device: hinged lid

SAP Code	00005200	Minimum device temperature [°C]	30
Net Width [mm]	269	Maximum device temperature [°C]	90
Net Depth [mm]	364	Number of GN / EN	2
Net Height [mm]	244	GN / EN size in device	GN 1/2
Net Weight [kg]	6.00	GN device depth	150
Power electric [kW]	1.000	Drain	Yes
Loading	230 V / 1N - 50 Hz		

Technical data sheet



Technical drawing

Sausage/vegetable steamer with tap GN 1/2

Model

SAP Code

00005200

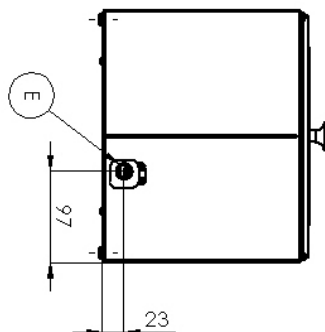
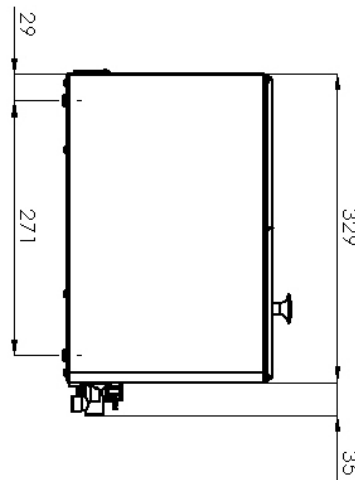
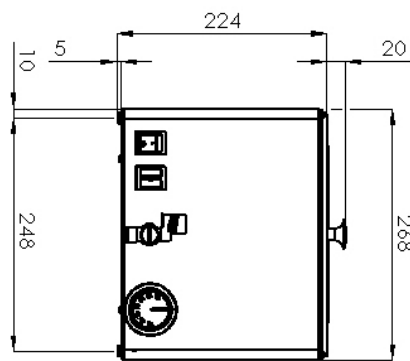

Technical data sheet



Product benefits

Sausage/vegetable steamer with tap GN 1/2

Model

SAP Code

00005200

1

All-stainless design

only stainless steel intended for food contact is used

- absolutely rust-proof and non-magnetic design
- resists even weak acids easier compliance with hygiene standards (HACCP); easy maintenance and cleaning

2

Capacity GN 1/2150

large capacity

- possibility to heat large quantities of sausages at once

3

Drain cock with safety lock

the possibility to drain the bath without the need for complex handling of the device

- easy draining of the water from the tub with the spout

4

Heaters outside the bath

heating element under the bottom of the bath

- the body is hidden under the bottom of the tub and cannot be accidentally damaged or injure the operator or burn the food

5

Warm-up indicator light

optical possibility to check the status of the device

- the operator immediately knows the on/off, heating/ non-heating state of the appliance

6

Removable / double bottom

enables the heating of sausages in steam

- there is no leaching of raw material into the water
- the raw material does not crack when cooked in water
- I don't have to heat so much water
- the food retains more of its flavour

7

Split hinged lid

the lid remains on the appliance
only the part where I manipulate is open

- less heat loss
- I don't need a space to store the lid
- safer handling

Technical data sheet



Technical parameters

Sausage/vegetable steamer with tap GN 1/2

Model

SAP Code

00005200

1. SAP Code:

00005200

2. Net Width [mm]:

269

3. Net Depth [mm]:

364

4. Net Height [mm]:

244

5. Net Weight [kg]:

6.00

6. Gross Width [mm]:

310

7. Gross depth [mm]:

450

8. Gross Height [mm]:

330

9. Gross Weight [kg]:

6.98

10. Device type:

Electric unit

11. Construction type of device:

Table top

12. Material:

Stainless steel

13. Power electric [kW]:

1.000

14. Loading:

230 V / 1N - 50 Hz

15. Standard equipment for device:

hinged lid

16. Number of GN / EN:

2

17. GN / EN size in device:

GN 1/2

18. GN device depth:

150

19. Minimum device temperature [°C]:

30

20. Maximum device temperature [°C]:

90

21. Protection of controls:

IPX4

22. Drain:

Yes

23. Indicators:

operation and warm-up

24. Heating location:

Under the bottom of the bathtub

25. False bottom:

Yes